

# Club Layout Specifications

## Contents:

1. Theory behind layout modules
2. Description of modules
3. Specifications of modules
4. Options available to club members wishing to make modules

## 1. Theory behind layout modules

The Club Layout consists of two concentric ovals of track that operate independently of each other. Each oval consists of a series of modules. The concept is designed so club members can make their own modules and either:

- a) replace a club module,
- b) sit adjacent to a club module,
- c) or add to the club modules and expand the size of the layout.

## 2. Description of modules

An examination of Figure 1 will reveal that the layout consists of several different size modules. The individual modules are outlined in pink boxes. Each is described below.

- a) **Yard Modules:** There are 3 yard modules. These are the same three yard modules we have had for years except the trolley line has been removed to lighten the weight and provide for easier storage. These modules measure 8 feet long by 30 inches in width and are 2.5 inches in height. (NOTE: These modules are of a different height than the other modules due to previous work done on the modules before the system described in these pages was conceptualized.)
- b) **Transition Modules:** There are 2 transition modules, one at each end of the yard, that transition the track from the 2.5 inch height of the yards to the 2.25 inch height of the rest of the modules.
- c) **Curved Modules:** The pink boxes are not shown on the curved modules because they are too hard to draw. Each 180 degree curve consists of two double track modules with 90 degrees of curve. These are 11 inches in width and 2.25 inches in height. The outer curve radius is approximately 10 feet and the inner approximately 9 feet. (NOTE: Possible plan for the future is to slit the second half of the curves into two single track sections each. This would allow the backside tracks to be spread apart.)
- d) **Backside Modules:**
  - i) **Backside Transition Module** — a single module to match the sum of the lengths of the 2 transition modules. It is of little consequence except that it has to be there.
  - ii) **Backside Modules** — These modules are where modules made by club members will fit. This is the part that is important to understand if you plan on making a module. These modules when combined match in length the 3 yard modules. That is, they total 24 feet in length. These modules are all single track. Therefore there are really 2 sets of modules 24 feet in length. Each single track section of backside modules consists of:
    - i. one 8 foot section
    - ii. one 6 foot section

- iii. two 4 foot sections
- iv. and one 2 foot section.

These can be arranged in any order. If no club member brings a module to a setup of the club layout, the club still has a complete layout. Any combination of modules (meeting the specifications below) can be accommodated. Obviously, any club member bringing a module must do so at the time of setup and must be there to retrieve the module at take-down.

### **3. Specifications of modules**

At this time we are only dealing with the backside modules. At some point in the future, if there is interest, we will deal with modules to go on the yard side and modules to extend the width of the layout as well as to separate the backside tracks.

Within the backside there are 2 types of modules that club members can build. They are modules WITH track and modules WITHOUT track.

#### **WITH Track:**

The specifications and diagrams below concern modules WITH track. Dimensions and how they were built are contained within the diagrams. You are free to build a module any way you wish but you must comply with the dimensions for the module to fit. At first glance the pink foamboard may seem to have no purpose. Actually, it adds rigidity to the module and deadens the sound of the wheels rolling across the track.

#### **WITHOUT Track:**

It is not necessary for a module to have track. A module could be a building with various details that sits next to the track. In this case the height dimension (2.25 inches) keeps the ground level consistent with everything else. Width and Length are not as important. That said, there are a couple of things to consider. If the Length matches the standard WITH Track modules of 2, 4, 6, or 8 feet there is less likely to be a conflict for space. If the Width is reduced to 17 inches then the back of the module will align with the modules containing track.

### **4. Options available to club members wishing to make modules**

Some options have already been mentioned; specifically modules WITH Track and modules WITHOUT Track.

Here are some other ideas:

- a. Modules can also be built WITHOUT Track to sit next to the yard.
- b. A new Trolley module would be a nice project. It could go from the yard to the backside.
- c. A lake module with trestle that both tracks cross. This would have to be modified if we divide the backside tracks.
- d. A backside siding and industry.
- e. A backside passing siding.
- f. Etc.

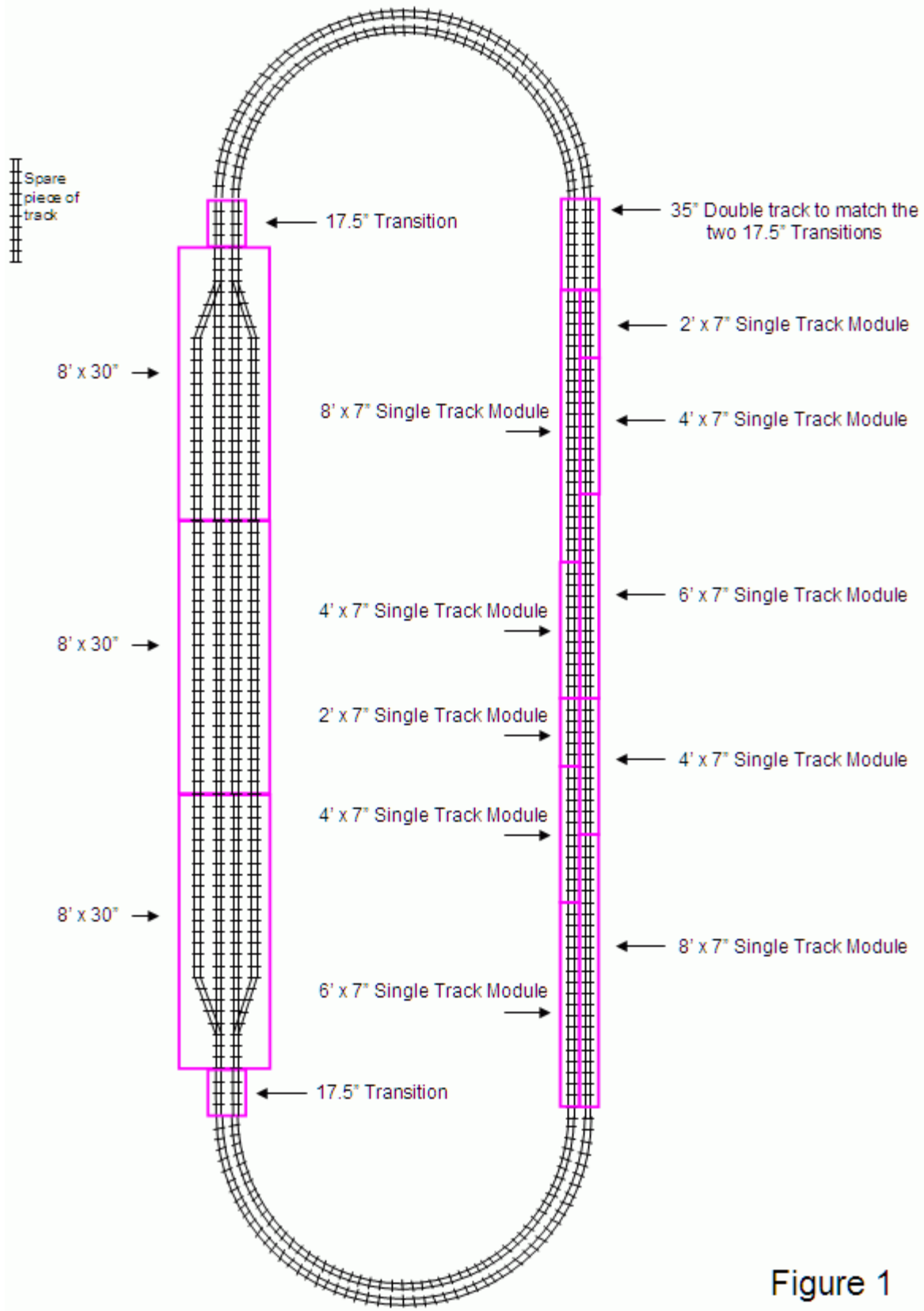
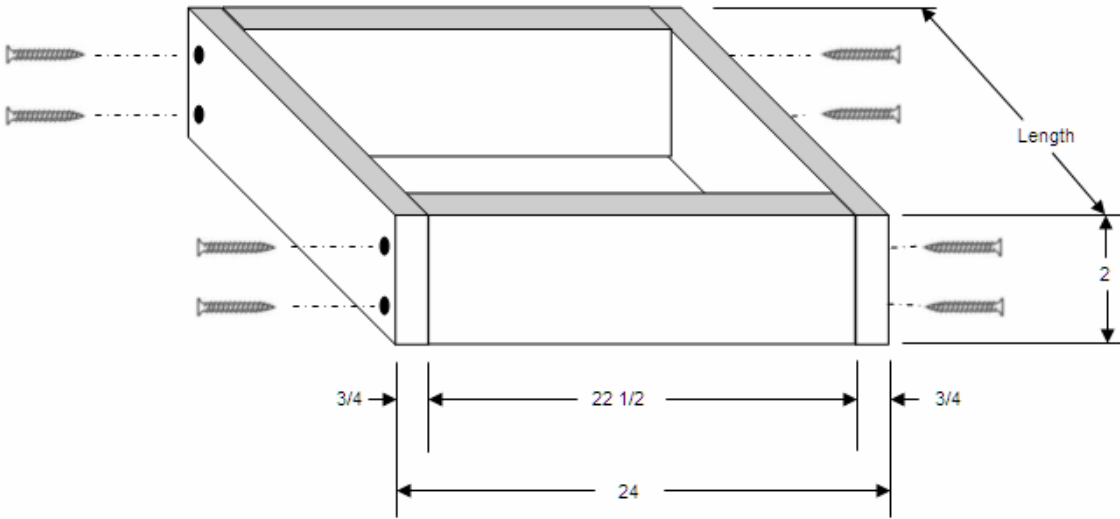

Figure 1



**Figure 2 – Frame**

The Frame is made by ripping southern yellow pine 1x6 into 2 inch widths. One 1x6 yields 2 strips of 2 inch wood and a piece of scrap.

Screws are Course Threaded Drywall screws of appropriate lengths. Be sure to drill and countersink all screw holes or you will split the wood making your dimensions incorrect. Length = 2 feet, 4 feet, 6 feet, or 8 feet. The choice is yours depending on the size module you want.

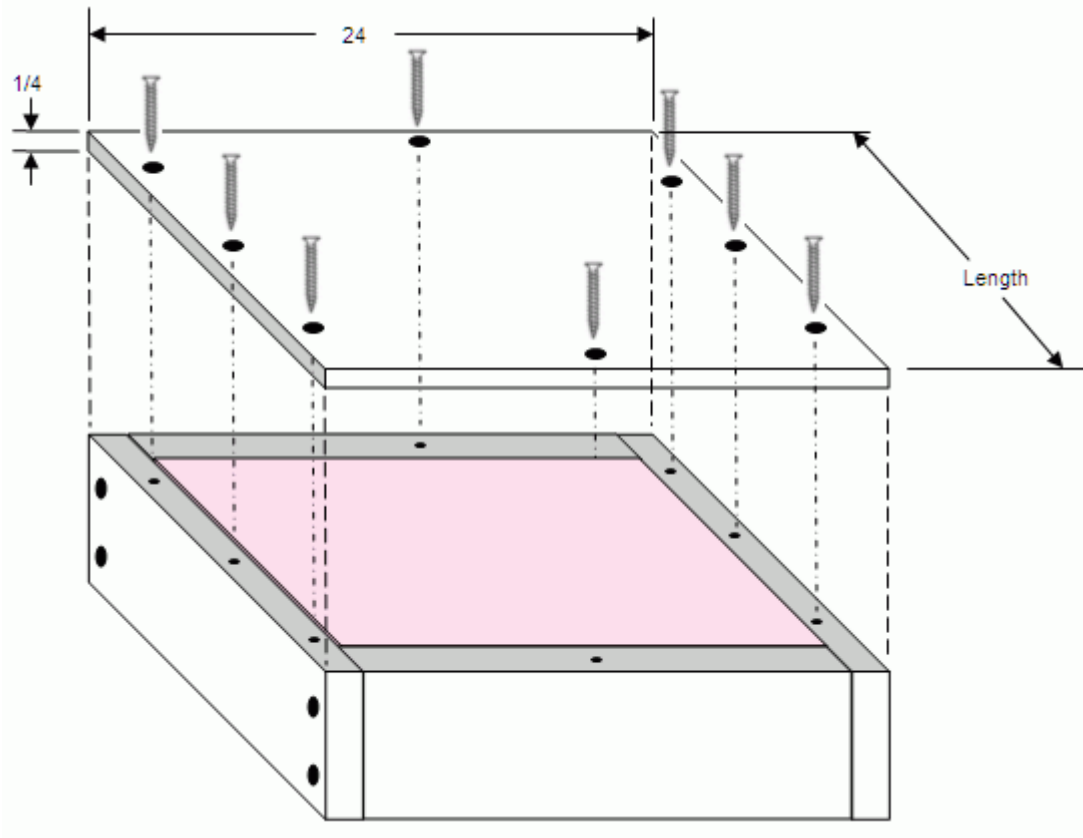

**Figure 3 – Top and Insert**

After the frame is completed a top of  $\frac{1}{4}$  inch Luane is added.

Screws are Course Threaded Drywall screws of appropriate lengths. Be sure to drill and countersink all screw holes or you will split the wood. Place screws about every foot.

The dimensions of the top should be 2 feet width by either 2 feet, 4 feet, 6 feet, or 8 feet Length. The choice is yours depending on the size module you want.

Once the top is fastened to the frame cut a piece of 2 inch thick foamboard (at Home Depot it is pink) and make sure it will fit into the bottom of the frame. DO NOT press it into the frame, just check the fit. Then place a bead of Liquid Nails for Projects and Foamboard inside the frame and against the underside of the top. Finally press your cut piece of foam into the frame. Turn the frame back over so it is right side up and walk around on the top to compress the Liquid Nails and ensure the foamboard is as far into the frame as possible.

Paint the top and sides a dark brown.

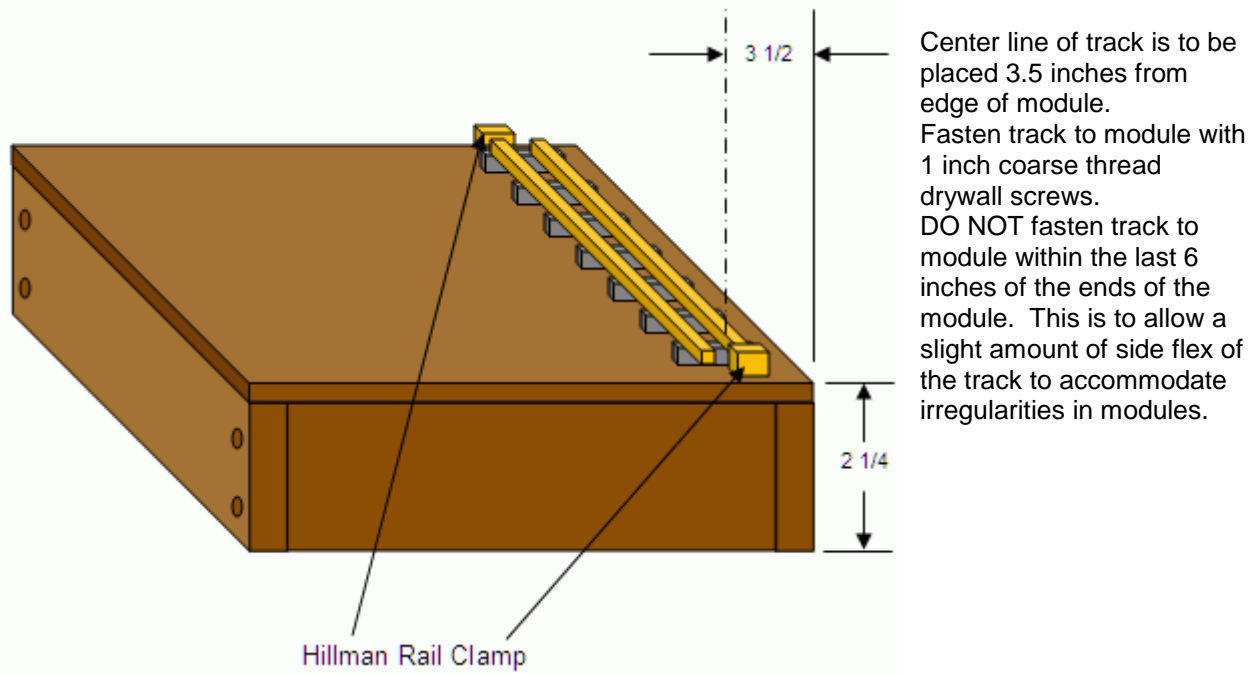

**Figure 4 – Track, Ground Cover, Ballast**

To cover the top of the module with something resembling ground cover, paint a thick coat of dark brown paint on the surface to be covered and immediately, while the paint is still very wet, sprinkle on your choice of ground cover (we used Woodland Scenics ground turf green blend). For track ballast we used Crushed Granite, Mount Airy, GRAN-I-GRIT Insoluble, Starter. We sprinkled it between the ties. We then spread it with a small dry paint brush to make sure it would not foul the wheel flanges. And finally soaked it with about a 4:1 mix of water and White Glue.

Each module is fastened to the adjacent module with Hillman Rail Clamps. The end of the rail should come just to the end of the module (no overhang). Leave enough room between the end of the rail and the last tie to slide the rail clamp back so it will not overhang the end of the module. This will help prevent the rail and/or rail clamp from catching on something and ripping the rail off or cutting the upholstery on your car.